

# Clarke®



**SUBMERSIBLE PUMP**  
**MODEL NO: DWP300A**  
PART NO: 7239220

**OPERATION & MAINTENANCE  
INSTRUCTIONS**



ORIGINAL INSTRUCTIONS

GC0819 - ISS 1

---

# INTRODUCTION

---

Thank you for purchasing this CLARKE submersible pump.

The pump is designed for domestic use, such as drying out basements and garages subject to flooding, and for pumping drainage wells, rainwater collecting traps etc.

Due to its compact shape, it is also used as a portable pump for emergency situations such as for drawing water from tanks or rivers, draining swimming pools and fountains, excavations or underpasses. Also suitable for gardening and general hobby activity.

This pump should not be used in swimming pools, ponds or hot tubs where people are present, or for pumping hydrocarbons (petrol, diesel fuel, combustible oils, solvents, etc) in accordance with the accident-prevention regulations in force.

It is not designed for continuous use, but for emergency use over a limited period and should be cleaned before putting away in storage. See the section "Maintenance".

## GUARANTEE

This product is guaranteed against faulty manufacture for a period of 12 months from the date of purchase. Please keep your receipt which will be required as proof of purchase.

This guarantee is invalid if the product is found to have been abused or tampered with in any way, or not used for the purpose for which it was intended.

Faulty goods should be returned to their place of purchase, no product can be returned to us without prior permission. This guarantee does not effect your statutory rights.

## ENVIRONMENTAL RECYCLING POLICY



Through purchase of this product, the customer is taking on the obligation to deal with the WEEE in accordance with the WEEE regulations in relation to the treatment, recycling & recovery and environmentally sound disposal of the WEEE.

In effect, this means that this product must not be disposed of with general household waste. It must be disposed of according to the laws governing Waste Electrical and Electronic Equipment (WEEE) at a recognised disposal facility.

# SPECIFICATIONS

Dimensions (L x W x H)	150 x 166 x 318/285 mm (handle raised/lowered)
Weight	4.2 kg
Cable Length	10 m
Power supply	230V ~ 50Hz
Ingress protection	IPX8
Outlet Thread Diameter	1¼" BSP female
Rated Power	330 W
Maximum Head Height	5.5 m
Maximum particle size	3 mm
Maximum Flow	130 l/min
Lowest residual water level	10 mm
Maximum Water Temperature	35°C

## PUMP PERFORMANCE CURVE

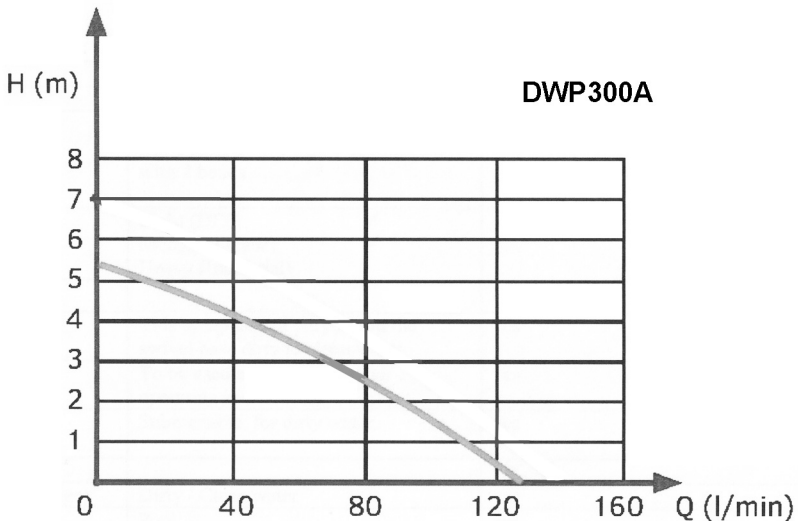

---

# SAFETY INSTRUCTIONS

---

## GENERAL

1. Read all instructions before use and save them for future use.
2. An approved residual current device (RCD) which has a tripping current of less than 30mA **MUST** be used for all operations.
3. The electrical supply must be the same as that on the rating plate.
4. ALWAYS make sure that your hands are dry when connecting or disconnecting from the mains supply.
5. NEVER pull the mains lead to disconnect the pump from the mains socket.
6. The mains plug must be kept away from the water at all times.
7. DO NOT allow children or unauthorised people to touch the pump, cables or connections.
8. Disconnect the pump from the mains supply when not in use.
9. If necessary have the pump repaired by a qualified person.
10. Keep the mains lead away from heat, oil and sharp edges.
11. If you have to use an extension lead with this product, it must be designed for outdoor use and incorporate a cable suitable for use with Class I appliances.
12. Disconnect the pump from the electrical supply and wear gloves during servicing or maintenance.

## PUMP SPECIFIC

1. Do not pump explosive / flammable liquids or chemicals.
2. NEVER allow the pump to run dry or operate out of the water.
3. Submersible pumps should always be submerged and stored vertically.
4. Disconnect the pump from the mains supply before placing it into or removing it from the water.
5. ALWAYS check the plug, and all cables for damage before use.
6. Do not use the pump if damaged. Refer to qualified service personnel for repair.
7. NEVER carry or lower the pump by the power cable or float switch always use the handle or a rope tied securely to the handle.
8. NEVER insert your fingers into the pump whilst it is connected to the mains.

9. NEVER use the submersible pump in a swimming pool when there are people or animals in the pool.
10. Keep the pump clear of any sediment by standing it on a platform or brick or suspending it at a suitable depth.
11. Do not use the pump if the water is liable to freeze, as this can cause damage to the pump. Remove the pump from the water and store it in a frost free location.

## ELECTRICAL CONNECTIONS



**WARNING: READ THESE ELECTRICAL SAFETY INSTRUCTIONS THOROUGHLY BEFORE CONNECTING THE PRODUCT TO THE MAINS SUPPLY.**

Connect the mains lead to a standard, 230 Volt (50Hz) electrical supply through an approved 13 amp BS 1363 plug or a suitably fused isolator switch. If the plug has to be changed because it is not suitable for your socket, or because of damage, it must be removed and a replacement fitted, following the wiring instructions shown below. The old plug must be discarded safely, as insertion into a power socket could cause an electrical hazard.



**WARNING: THE WIRES IN THE POWER CABLE OF THIS PRODUCT ARE COLOURED IN ACCORDANCE WITH THE FOLLOWING CODE:  
BLUE = NEUTRAL    BROWN = LIVE    YELLOW AND GREEN = EARTH**

If the colours of the wires in the power cable do not agree with the markings on the plug.

- Connect the BLUE wire to the terminal marked N.
- Connect the BROWN wire to the terminal marked L .
- Connect the YELLOW AND GREEN wire to the terminal marked E or  $\perp$  .

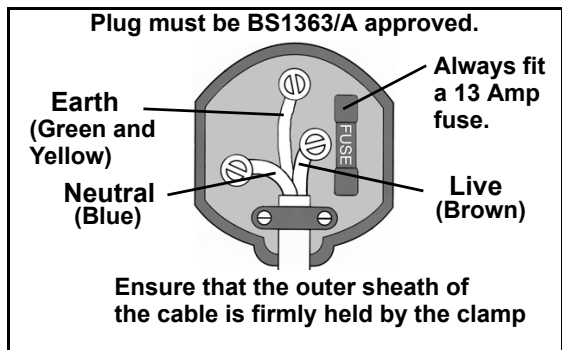

**AN APPROVED RESIDUAL CURRENT DEVICE (RCD) WHICH HAS A TRIPPING CURRENT OF LESS THAN 30 mA MUST BE USED.**

If you are not sure, consult a qualified electrician. DO NOT try to do any repairs.

## INSTALLING THE PUMP

Remove all packaging and make sure that the pump has no visible damage. Dispose of all packaging appropriately.

### FITTING THE ELBOW

1. Screw one of the elbows into the outlet port as shown. Two elbows are supplied;
  - Threaded elbow
  - Push-fit elbow

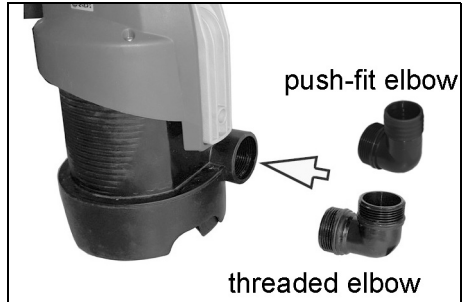

### FITTING THE STEPPED ADAPTER

The stepped hose adaptor supplied is designed to be used for either screw type hose connection or push fit.

- stepped adaptor for 1 ½" BSP / 1" BSP hose (hose not supplied)
1. Screw the adaptor to the threaded elbow and connect a suitable hose (not supplied) to either the screwed end or push-fit
    - Suitable hoses are available from your local Clarke dealer.
    - The adaptor can be cut off with a hacksaw to provide clearance if required, when a larger hose is to be used.
  2. Trim the adaptor to size if required.
    - Reducing the hose diameter will affect the maximum flow rate.
  3. When push fitting the hose to the adaptor or elbow, use a jubilee clip to secure it. Do not overtighten.



## POSITIONING THE PUMP

1. Stand the pump upright on a flat surface in the pool that you want to drain. If there is sediment in the pool or pond, place the pump on blocks, to avoid blocking the water inlet.
2. Set the height of the pump inlet by extending and twisting the base (foot) if required. With the base retracted the pump can remove all but the remaining 10 mm of water. With the base extended the pump can pick up more solids in suspension.
3. Ensure the pump is positioned with adequate space - recommended minimum base area of 20 x 25 cm and the maximum depth of any installation - 5.5mtr. The pump is supplied with 10 metres of power cable.
4. Always raise and lower the pump using the lifting handle and a rope attached to it if required. Never lift or lower the pump using the power cable.
  - The water inlet must be fully submerged before the pump is switched on and the pump be standing upright.
5. Connect the power cable to a high sensitivity residual current device (RCD) which has a tripping current of less than 30mA.

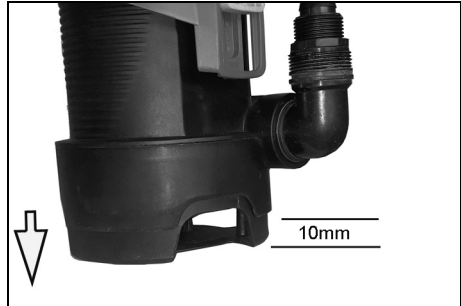

---

## OPERATING THE PUMP

---



**WARNING: CHECK THE PUMP FOR DAMAGE BEFORE USE, DO NOT USE THE PUMP IF IT IS DAMAGED IN ANY WAY.**

---

1. Switch the mains power supply on.
  - The pump will begin to drain water.
  - As the water level falls, so will the float switch, until it stops the pump.
  - You can set the position of the float switch using the clip on the side of the pump. Adjusting the length of the float switch lead will change the depth of water at which the pump will turn on or off.

- The pump can be kept running continuously by positioning the float in the raised position but it will need to be stopped manually by lowering the float or unplugging the power cable. This method can be used to scavenge the last of the remaining water to the 10mm limit.
- When pumping is finished, disconnect the pump from the power supply.

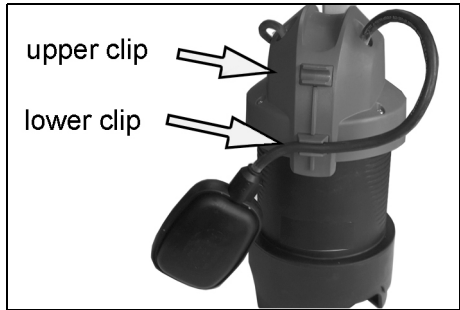

CAUTION: DO NOT ALLOW THE PUMP TO RUN DRY

- The pump is fitted with a thermal overload switch. If the pump overheats for any reason, it will automatically switch the pump OFF. Once the pump has cooled (at least 5-10 minutes), it will automatically restart.

## AFTER USE

When the temperature is expected to be lower than 0°C, ensure there is no residual water which could freeze, causing damage to the pump.

If the pump has been used with substances that tend to form a deposit, or with water containing chlorine, rinse it after use with a powerful jet of water in order to avoid the formation of deposits or encrustations which would reduce the performance of the pump.

## MAINTENANCE



**WARNING: BEFORE CHECKING THE CONDITION OF THE PUMP, ENSURE IT IS UNPLUGGED FROM THE MAINS SUPPLY. IF THE UNIT IS HARD WIRED, ENSURE THE CIRCUIT BREAKER IS OPEN.**

This pump should require no maintenance other than regular cleaning. If the pump shows signs of wear or damage contact your CLARKE dealer for advice.

Check the pump regularly to ensure the water inlet is clear of leaves or other debris. If foreign material has been drawn into the pump inlet, further cleaning may be required by back-flushing the pump with water pressure from a hose.



# TROUBLESHOOTING

PROBLEM	SOLUTION
PUMP WILL NOT START	<ol style="list-style-type: none"> <li>1. Make sure that the power is switched on.</li> <li>2. Check fuse (consult an electrician if in doubt).</li> <li>3. If extension lead is used, check connections (consult an electrician if in doubt).</li> <li>4. Internal thermal cut-out has not re-set. Leave for 5-10 minutes and try again.</li> <li>5. The impeller may be jammed. Disconnect from the mains supply and remove any objects that may be obstructing the impeller.</li> <li>6. Float switch may be jammed against side wall, or prevented from moving.</li> <li>7. Water level too low - float switch in OFF position - lift float to check switch.</li> <li>8. If the pump still fails to start, consult your CLARKE dealer for advice.</li> </ol>
PUMP WILL START BUT NOT PUMP	<ol style="list-style-type: none"> <li>1. Check that the inlet is not blocked.</li> <li>2. Check that the discharge tube is not clogged or obstructed.</li> <li>3. The head may be too great, i.e. you are trying to lift the water too great a distance for the pump to cope with Specifications on page 2.</li> <li>4. Air bubble in the pump, produced during the plunge. Plunge the pump again, at an angle, and shake it whilst lowering to remove any air trapped in the system.</li> <li>5. Impeller may be damaged - Consult your CLARKE dealer.</li> </ol>
PUMP WILL NOT STOP	<ol style="list-style-type: none"> <li>1. Float switch may be prevented from moving to the fully down position.</li> <li>2. Float switch may be faulty. Consult your CLARKE dealer for advice.</li> </ol>
PUMP STOPS RUNNING	<ol style="list-style-type: none"> <li>1. Thermal overload has operated. Leave for 5-10 minutes and try again.</li> <li>2. Pump has run dry or float switch has cut in.</li> <li>3. A foreign object has jammed the impeller.</li> </ol>

If this does not solve your problem, please contact the CLARKE service department. Do not attempt to repair the pump yourself. Repairs must be carried out by your CLARKE dealer.

# PARTS DIAGRAM

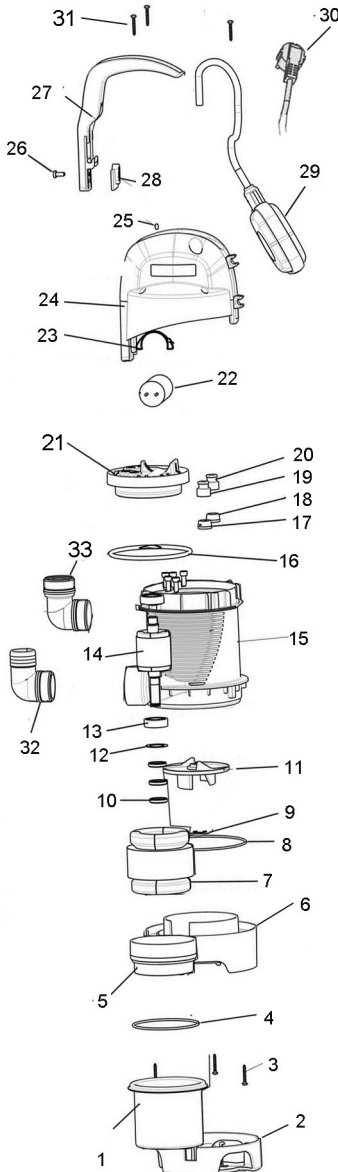

Ref No	Description
1	Lower insert
2	Foot moulding
3	Screw
4	O-ring
5	Upper insert
6	Lower enclosure
7	Motor stator
8	Sealing ring
9	Clip
10	O-ring set
11	Impeller
12	O-ring
13	Motor Bearing
14	Motor rotor
15	Main housing
16	Sealing ring
17/18	Collet
19/20	Bush
21	Upper enclosure
22	Capacitor
23	Clip
24	Upper cover
25	Gland
26	Screw
27	Handle
28	Handle slide clip
29	Float Switch
30	Power cable/plug
31	Screw
32	Elbow - (push on)
33	Elbow - (threaded)

# DECLARATION OF CONFORMITY



**Clarke**<sup>®</sup>  
**INTERNATIONAL**

Hemnal Street, Epping, Essex CM16 4LG

## DECLARATION OF CONFORMITY

**This is an important document and should be retained.**

**We hereby declare that this product(s) complies with the following directive(s):**

2014/30/EU      *Electromagnetic Compatibility Directive.*  
2014/35/EU      *Low Voltage Equipment Directive.*  
2011/65/EU      *Restriction of Hazardous Substances.*

**The following standards have been applied to the product(s):**

*EN 60335-1:2012+A11:2014, EN 60335-2-41:2003+A2:2010.*

The technical documentation required to demonstrate that the product(s) meet(s) the requirement(s) of the aforementioned directive(s) has been compiled and is available for inspection by the relevant enforcement authorities.

The CE mark was first applied in: 2019

**Product Description:**            Sub Clean / Dirty Water Pump 330W  
**Model number(s):**            DWP300A  
**Serial / batch Number:**        N/A  
**Date of Issue:**                31/05/2019

**Signed:**

**J.A. Clarke**  
**Director**

# A SELECTION FROM THE VAST RANGE OF

# Clarke®

## QUALITY PRODUCTS

### AIR COMPRESSORS

From DIY to industrial, Plus air tools, spray guns and accessories.

### GENERATORS

Prime duty or emergency standby for business, home and leisure.

### POWER WASHERS

Hot and cold, electric and engine driven - we have what you need

### WELDERS

Mig, Arc, Tig and Spot. From DIY to auto/industrial.

### METALWORKING

Drills, grinders and saws for DIY and professional use.

### WOODWORKING

Saws, sanders, lathes, mortisers and dust extraction.

### HYDRAULICS

Cranes, body repair kits, transmission jacks for all types of workshop use.

### WATER PUMPS

Submersible, electric and engine driven for DIY, agriculture and industry.

### POWERTOOLS

Angle grinders, cordless drill sets, saws and sanders.

### STARTERS/CHARGERS

All sizes for car and commercial use.



**PARTS & SERVICE: 0208 988 7400**

**E-mail: [Parts@clarkeinternational.com](mailto:Parts@clarkeinternational.com) or [Service@clarkeinternational.com](mailto:Service@clarkeinternational.com)**

**SALES: UK 01992 565333 or Export 00 44 (0)1992 565335**

**Clarke INTERNATIONAL** Hemnall Street, Epping, Essex CM16 4LG  
[www.clarkeinternational.com](http://www.clarkeinternational.com)